

### Three Phase Squirrel Cage Induction Motor

Motor type TA3-132M2-6 B3



#### Electrical Data

RATED VALUES							STARTING VALUES				BREAKDOWN	EFFICIENCY			EFFICIENCY CLASS
VOLTAGE	POWER		SPEED	CURRENT	TORQUE	Cos φ	CURRENT		TORQUE		TORQUE	%			IEC 60034-30-1
V	kW	Hz	rpm	A	Nm	4/4	I <sub>A</sub> / I <sub>N</sub> Y D	M <sub>A</sub> / M <sub>N</sub> Y D	Mk/ Mn Nm			4/4	3/4	2/4	IE
400/690	5,5	50	970	12.1/7.0	54,15	0,75	1,8	5,45	0,5	1,5	2,6	IE3-88,0%	88,7	88	IE3
460/795	6,33	60	1170	11.85/6.85	51,63	0,76	1,8	5,287	0,5	1,43	2,5	-	-	-	

#### Mechanical Data

Bearing DE	6208-ZZ	Color	RAL 7030
Bearing NDE	6208-ZZ	Motor protection	No
Lubricants	Shell Gadus S5 V220-2	Method of cooling	IC 411
Condensation drain hole	No	Terminal box position	Top
External earthing terminal	Yes	Material of terminal box	Aluminium
Vibration class	A	Terminal plate thread	M6
Insulation Class	F	Cable gland	1xM32
Duty type	S1	Clamping range	18-25 mm
Direction of rotation	Clockwise	Mounting type	IM 1001 (B3)
Housing material	Aluminium		
Type of balancing	Half Key		

#### Environmental Data

#### Others

Ambient Temperature	-20 / + 40 °C	Type of protection	IP 56
Altitude above sea level	1000 m	Sound Pressure Level 50/60Hz dBA	60/63
		Moment of Inertia (kg.mm <sup>2</sup> )	0,0594
		Standard	IEC 60034-1
		Weigh (Kg)	82

#### Dimensions

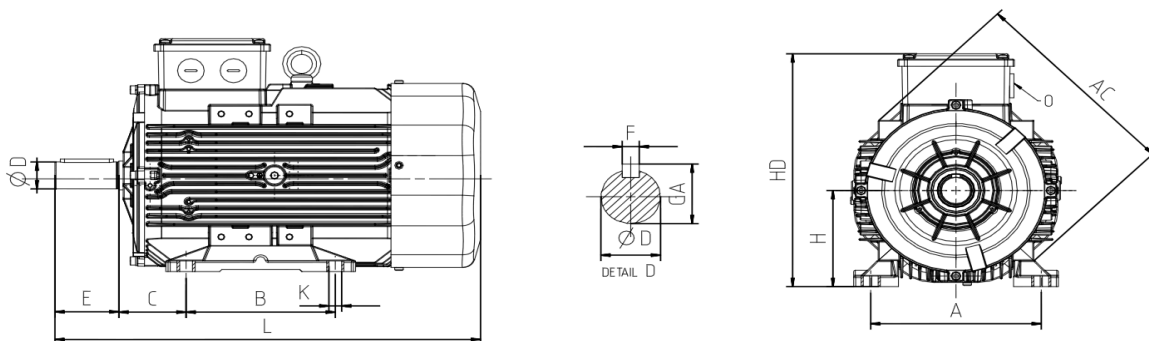

Main Dimensions		Foot Mounted Motors						Shaft				Flange Mounted Motors			
AC	L	B	A	H	HD	K	C	D	E	GA	F	P	N	M	R
260	481	140-178	216	132	322	12	89	38	80	41	10	0	0	0	0